



PRESSURE SENSING SWITCHES WITH FIXED SET POINT

APPLICATION

Model FS-BO airflow proving switches are designed for duct heater, oven, and other HVAC or Energy Management applications which require a nonadjustable switch. They are suitable for surface-mounting in areas where internal access is limited. FS-BO switches are used to sense positive air pressure. Various mounting configurations, electrical connections, and sample line connections are available.

GENERAL DESCRIPTION & OPERATION

The plated housing contains a diaphragm and a snap-acting switch.

The sample line connection is situated on the positive side of the diaphragm. Rigid or flexible tubing connections are available. The standard electrical connection consists of male 1/4" quick-connect spade terminals.

The snap-action switch operates on pressure rise of 0.05" w.c., ± 0.02 " w.c. For additional application and technical information, including custom feature availability, please contact the sales office.

MOUNTING (FIGURE 1)

Select a mounting location which is free from vibration. The switch must be mounted with the diaphragm in any vertical plane in order to maintain the specified operating set point. Avoid mounting with the sample line connection in the "up" position. The standard model surface-mounts via the two 3/16" diameter holes on the zinc-plated strap bracket. The mounting holes are 3-7/8" apart. Custom mounting configurations are available.

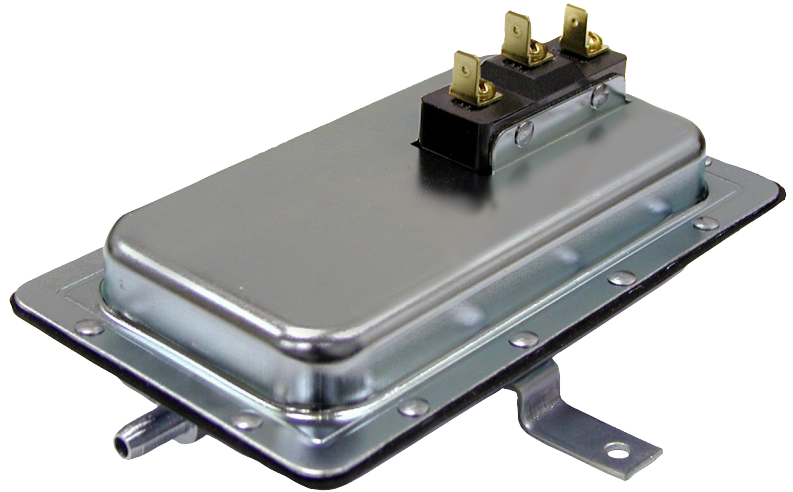

AIR SAMPLING CONNECTION (FIGURE 2)

FS-BO switches are equipped with a sample line connection situated on the positive side of the diaphragm as shown in Figure 2. Locate the sampling probe a minimum of 1.5 duct diameters downstream from the air source. Install the sampling probe as close to the center of the airstream as possible.

ELECTRICAL CONNECTIONS (FIGURES. 2 & 3)

Before pressure is applied to the diaphragm, the switch contacts will be in the normally closed (NC) position as shown in **Figure 2**.

Control and alarm functions are wired as shown in **Figure 3**.

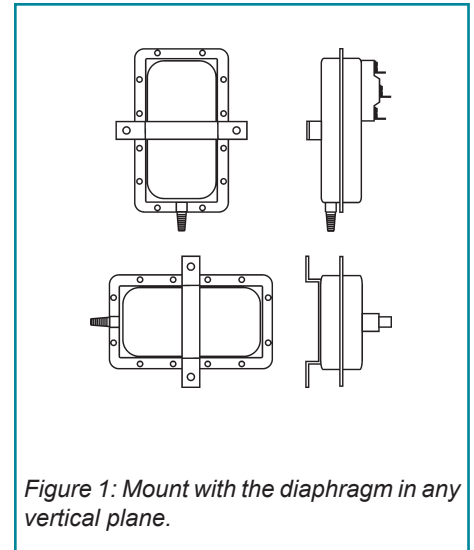

Figure 1: Mount with the diaphragm in any vertical plane.

Figure 2

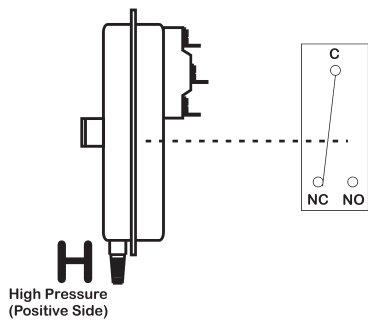
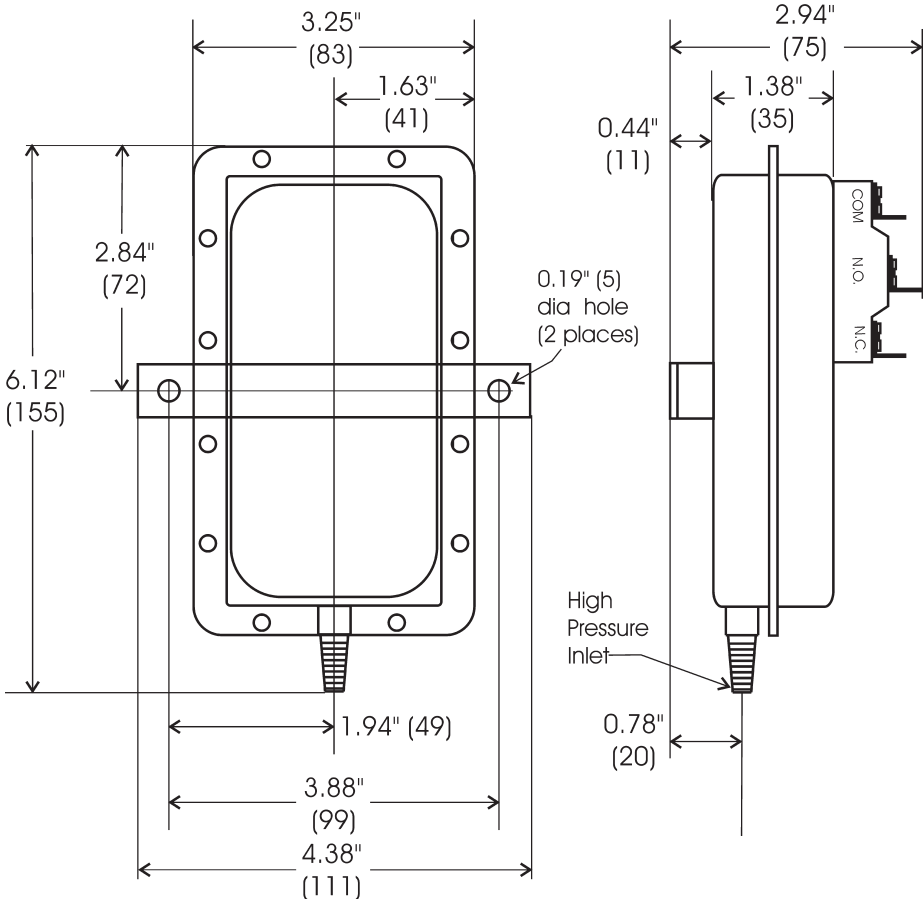
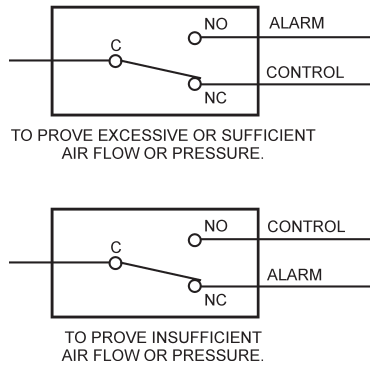

Figure 3



Dimensions in Inches (Millimeters)

SPECIFICATIONS

SERIES FS-BO AIR PRESSURE SENSING SWITCHES WITH FIXED SET POINT

Mounting Position:

- Mount with the diaphragm in any vertical plane

Set Point Range:

- Fixed to operate on **pressure rise** or **vacuum fall** at 0.05 ± 0.02 "w.c. (1.27 ± 0.508 mm)

Approximate Switch Differential:

- 0.02 ± 0.01 "w.c. (0.508 ± 0.254 mm w.c.)

Measured Media:

- Air or combustion by-products that will not degrade silicone

Maximum Pressure:

- ½ psi (0.03 bar)

Operating Temperature Range:

- -40 to 180 °F (-40.0 to 82.2 °C)

Life:

- 100,000 cycles minimum at ½ psi maximum pressure each cycle and at maximum rated electrical load

Electrical Rating:

- 300 VA pilot duty at 115 to 277 VAC
- 15 amp noninductive to 277 VAC, 60 Hz.

Contact Arrangement Options:

- SPDT
- SPST-NO
- SPST-NC

Electrical Connections:

- ¼"-90° male quick-connect spade terminals

Sample Line Connector Options:

- externally threaded 7/16" UNS 2A thread with nut and self-aligning ferrule
- 1/8" - 27NPT female thread for pipe connection
- ¼" OD tube – for slipping on flexible type tubing
- ¼" OD barbed, suitable for flexible plastic tubing

Approvals:

- UL, CSA, and FM

Shipping Weight:

- 1.2 lb.